



**SAFE  
WORK**

**S  
A  
F  
E**  
SPOT THE HAZARD  
ASSESS THE RISK  
FIND A SAFER WAY  
EVERYDAY

**EVERYONE'S  
RESPONSIBILITY**



# Guideline for Excavation Work

December 2007

Manitoba 

# Guideline

## for Excavation Work



Workplace Safety & Health Division  
200 – 401 York Avenue  
Winnipeg, Manitoba  
R3C 0P8

December 2007

Manitoba 



## Guideline for Excavation Work Table of Contents

<b>INTRODUCTION</b> .....	<b>2</b>
Introduction .....	2
Workplace Safety and Health Regulation Requirements .....	2
<b>DEFINITIONS</b> .....	<b>3</b>
<b>HAZARDS TO WORKERS NEAR EXCAVATION SITES</b> .....	<b>4</b>
Cave-Ins or Excavation Collapses .....	4
Excavated Material .....	5
Falling Objects or Objects near an Excavation .....	5
Powered Mobile Equipment .....	6
Slips, Trips, and Falls.....	7
Hazardous Atmospheres .....	7
Flooding/Water Hazards .....	8
Underground Facilities.....	8
<b>BEFORE YOU EXCAVATE</b> .....	<b>10</b>
Becoming a Registered Excavation Contractor .....	10
Obtaining a Serial Number for Excavations from the Workplace Safety and Health Division.....	11
Obtaining Clearances from Underground Facilities .....	11
Requirement for Engineering Approvals .....	12
Training for workers .....	12
<b>LEGAL REQUIREMENTS AT EXCAVATION SITES</b> .....	<b>14</b>
Other Legislation.....	15
Quick Reference for Soil Categories .....	16
<b>SOIL PROPERTIES</b> .....	<b>17</b>
Soil Categories specific to Manitoba.....	17
Manitoba Soil Types .....	18
Cohesionless Soils .....	20
Bedrock.....	21
Types of Soil Collapse .....	22
<b>EXCAVATIONS</b> .....	<b>24</b>
Sloped Excavations .....	26
Temporary Support Structures/Shoring .....	27
Shoring Table.....	28
Installation of Shoring .....	29
Proper Procedures for Installing Shoring.....	30
Removal of Shoring .....	31
Prefabricated Support Systems (Trench Cages) .....	32
Hydraulic/Pneumatic Support Systems .....	33
Additional Considerations for Open Excavations.....	34
<b>SHAFT AND TUNNEL EXCAVATIONS</b> .....	<b>36</b>
Housekeeping.....	37
Falls .....	37
Access/Egress .....	37
Atmosphere Conditions .....	38
Fire Protection .....	38
Explosives.....	38
Communication.....	38
Machinery & Equipment.....	39
<b>DEEP FOUNDATION EXCAVATIONS</b> .....	<b>40</b>
<b>PILE DRIVING</b> .....	<b>42</b>
Types of hammers .....	42
Safe Work Practices and Procedures.....	46
Professional Engineer Approval and Inspection .....	46

# INTRODUCTION

## Introduction

Excavation work is hazardous. This guideline provides information on the potential hazards involved in excavation work so that workers and employers can work together to create a safe, injury and fatality free worksite.

## Workplace Safety and Health Regulation Requirements

The *Workplace Safety and Health Act* and Part 26 of the Manitoba Workplace Safety and Health Regulation, M.R. 217/2006, require specific actions when planning and performing excavation work.

This guideline provides general information on legal requirements before performing excavation work, hazards to workers near excavation sites, support systems, shaft and tunnel excavations, deep foundation excavations, pile driving and Manitoba soil properties.

## DEFINITIONS

- **Deep Foundation** means a foundation unit that provides support for a building or structure by transferring loads either by end bearing to soil or rock at substantial depth below the building or structure, or by adhesion or friction or both, in the soil or rock in which it is placed, and includes a pile or caisson.
- **Excavation** means a dug out area of ground and includes a deep foundation excavation, trench, tunnel and shaft.
- **Open excavation** means an excavation in which the width is greater than the depth, measured at the bottom.
- **Pile or Caisson** means a slender, deep foundation unit made of materials or a combination of materials, such as wood, steel or concrete, which is either pre-manufactured and placed by driving, jacking, jetting or screwing, or cast in place in a hole formed by driving, excavation or boring.
- **Professional engineer** means a person who is a member of the Association of Professional Engineers and Geoscientists of the Province of Manitoba, and holds a valid certificate of registration under The Engineering and Geoscientific Professions Act, or who is a non-resident and holds a valid temporary license granted under The Engineering and Geoscientific Professions Act.
- **Shaft** means a vertical or inclined opening that leads to an underground working and is excavated below ground level.
- **Shoring** is an assembly of structural members designed to prevent earth or material from falling, sliding or rolling into an excavation.
- **Support structure** means a temporary or permanent structure or device designed to provide protection to workers in an excavation, tunnel or shaft from cave-ins, collapse, sliding or rolling materials and includes shoring, bracing, piles, planks and trench cages.
- **Trench** means an excavation that is deeper than its width measured at the bottom.
- **Trench Cage** means a steel support structure designed to resist the pressure from the walls of a trench and capable of being moved as a unit.
- **Trench Jack** means a screw or hydraulic jack used as a brace for a temporary support structure.
- **Tunnel** means a generally horizontal excavation that is more than a metre long and located underground.

# HAZARDS TO WORKERS NEAR EXCAVATION SITES

The most common hazards that exist in excavation work include:

- cave-ins or excavation collapses
- excavated material
- falling objects or objects near an excavation
- powered mobile equipment
- slips, trips, and falls
- hazardous atmospheres
- flooding/water hazards
- underground facilities

## Cave-Ins or Excavation Collapses

Why do serious worker injuries and fatalities continue to occur in the excavation industry?

It is because both employers and workers often forget that when they remove earth from the ground it creates an opening, and the remaining earth surrounding the opening tends to relax. This increases the pressure towards the walls of the opening and makes the ground collapse. Water in the soil or ground also affects the stability of the walls by putting additional pressure on the walls and increasing the possibility of a cave in. Unless a horizontal distance equal to the vertical depth of the excavation walls is maintained, engineering controls must be used (ex: shoring, trench cages) to provide a safe and healthy workplace within the excavation area.

### REMEMBER

No one can predict that an excavation is safe to enter without ensuring the walls of the excavation are sloped at 45 degrees or using a proper support structure.

Victims buried in an excavation collapse may suffocate. Even workers only buried up to their waist have died because of the pressure exerted by the soil on their bodies. Survivors often receive severe crushing injuries.

Excavations in or near backfilled (previously excavated) ground are especially dangerous since the previously disturbed soil is "loose," and not self-supporting.

In addition, clay can be extremely treacherous if dried by the sun. Large chunks of clay can break off a trench wall after having been stable and solid for a long period.

Furthermore, during winter months, it is not safe to assume that an excavation is safe to enter because the walls are frozen. Frozen ground is not an alternative to proper, temporary support structures.

## Excavated Material

Injuries may also occur in excavation work when excavated material on the surface of the excavation is too close to the edge and falls into the excavation, or affects the structural stability of the walls of the excavation.

Pile all excavated material so that the material cannot roll back into the excavation. The material must never be closer than one metre (three feet) from the edge of the excavation, and should be placed as far away as possible so it does not affect the structural stability of the walls. Ideally, the excavated material should be placed as far away from the edge of the vertical excavation as the excavation's height ( $d \geq h$ : see diagram below).

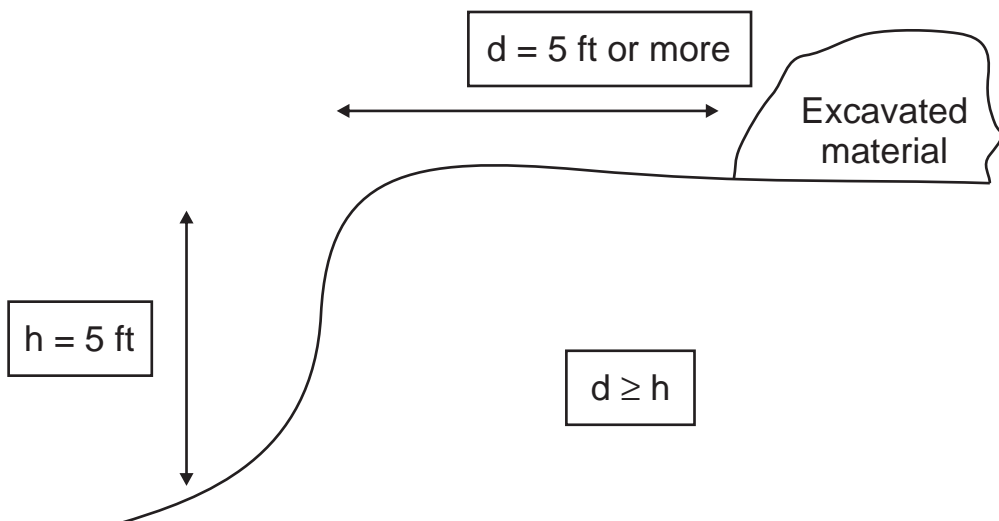

## Falling Objects or Objects near an Excavation

Place tools and equipment used at the excavation site so that they cannot fall into the excavation or affect the structural stability of the walls of the excavation. Use barriers to help keep tools and equipment at a safe distance from the edge of the excavation. Use ropes or other lowering devices to transport the tools or equipment into the excavation.



## Powered Mobile Equipment

Workers may be exposed to hazards when powered mobile equipment is used near an excavation site. Powered mobile equipment includes backhoes, track hoes, concrete trucks, trucks removing excavated material and others. Common hazards related to powered mobile equipment include:

- equipment placed close to the edge of an excavation may cause the excavation walls to become unstable. Powered mobile equipment can be placed near the edge of the excavation if a support structure, designed to consider the overload from the equipment, is installed in the excavation.
- equipment vibration puts additional pressure on excavation walls, affecting the structural stability.
- equipment operating on rough terrain, or too close to the edge of an excavation, may roll over and fall into the excavation. Ensure all equipment is equipped with roll over protective structures (ROPS).
- workers riding on equipment without approved seats may be injured.
- workers getting on and off equipment are at risk because balance can be affected by the vibration of the equipment. A worker may not be as sure footed getting off the equipment after operating it for a period of time.
- workers may be injured by equipment. A safe distance must be maintained from moving equipment at all times. Operators must be aware of all workers near their work area.

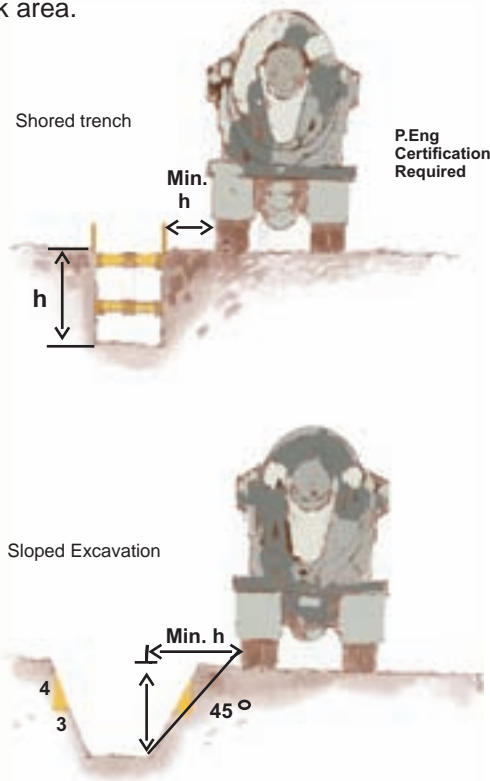

## Slips, Trips, and Falls

Slip, trip and fall hazards are common around excavations. Examples include:

- excavation entrances and exits. A safe means of entering and exiting an excavation is required. Specifically, where an excavation is more than 1.5 metres (five feet) deep, a stairway, ramp or ladder is required. Workers must use both hands when climbing up or down ladders. Tools or equipment should not be carried up or down the ladder. In addition, the ladder must:
  - ▶ meet the standards outlined in Part 21 of the Workplace Safety and Health Regulation, respecting Entrances, Exits, Stairways and Ladders
  - ▶ extend one metre above the edge of the excavation
  - ▶ be located no more than three metres (10 feet) away from the workers inside the excavation
- uneven ground surfaces around or inside an excavation. It is important that a housekeeping program is in place and every effort is made to ensure walkways and pedestrian traffic areas are maintained.
- excavation edges are a risk to people working near them:
  - ▶ employees working near the edge of the excavation edge need to be protected by a means of fall restraint or fall protection.
  - ▶ walkways constructed for use over an excavation must be built and maintained for safe use by workers. Guardrails must also be in place so that a worker cannot fall from the walkway into the excavation.
  - ▶ employees working around an excavation site are at risk of falling into the excavation. Adequate protection must be provided for those workers as well as pedestrian traffic that may come near the edge of the excavation.

## Hazardous Atmospheres

Hazardous atmospheres at excavation site may come from soils that are moved or from pipes and conduits disturbed during excavation. Where there is a potential for a hazardous atmosphere, a plan must be developed to ensure the workers in or near the excavation are not at risk. The plan must include the following steps:

- **Pre-Work Testing** – The atmosphere must be tested before anyone enters the excavation to ensure they won't be exposed to hazards. Common atmospheric hazards include gasoline vapours, methane or other explosive gases and a lack of oxygen.
- **Controlling the Hazard** – When an atmospheric hazard is present, the first priorities must be to eliminate or control both the hazard and entry to the excavation. Ventilation must be installed, operated and maintained to ensure worker protection. If ventilation is not practical, the worker must be provided with personal protective equipment suitable to protect against the hazard. For example, when there is a lack of oxygen, the worker must be provided with an approved self-contained breathing apparatus (SCBA) that provides adequate oxygen.

- **Periodic Testing** – Periodic tests must be conducted to ensure the hazardous atmosphere is controlled and that workers are protected. All testing must be done by qualified personnel who have the knowledge and expertise required to keep workers safe. All tests conducted must be:
  - ▶ recorded
  - ▶ kept at the excavation site
  - ▶ made available to the workers upon request

## Flooding/Water Hazards

Because of the condition or location of excavation sites, water hazards may be present, including:

- **Flooding** – An excavation may flood if the work is below the water table, near a watercourse bank or exposed to adverse weather conditions. When there is a risk of flooding, an emergency evacuation plan must be developed. The plan will include a full body harness with a lifeline (that meets the requirements of Part 14 of the Workplace Safety and Health Regulation, relating to fall protection) to be worn by workers in the excavation. Workers must also have direct communication with the person located at the surface of the excavation.
- **Water Accumulation** – This may be caused by an excavation near a ground water source, in wet conditions or because of equipment that uses water for operation near the excavation site. Water accumulation must be kept to a minimum to reduce risks such as slipping or tripping hazards, electrical hazards, equipment malfunctions or others.

## Underground Facilities

Common underground facilities include:

- electrical lines
- oil and gas lines
- telecommunication lines (phone, cable, computer)
- water and sewer lines
- traffic signal lines
- steam lines

Special attention must be given to the hazards associated with underground facilities. Before beginning excavation work, proper planning must identify the location of underground facilities and any precautions needed to avoid contact with these facilities.

To ensure that all hazards are identified, owners of underground facilities must be notified prior to starting excavation work. The owners of the underground facilities must issue clearances or specific instructions to the contractor. These clearances

and instructions must be available on site for further reference. If any pipe, conduit or cable that is not supposed to be worked on is contacted during excavation work, the workers must be immediately evacuated from the excavation until all hazards or unsafe conditions are identified and corrected. The owner of the facility must also be notified.

Special consideration must also be given to prevent contact with overhead electrical lines. If mobile equipment used in excavation work is capable of coming within three metres (10 feet) of an overhead electrical line, please refer to the requirements under Part 25 of the Workplace Safety and Health Regulation, M.R. 217/2006.

## BEFORE YOU EXCAVATE

There are a few things to consider in the planning stages of excavation work. Before you begin your excavation work, you must ensure that you have:

- registered as an excavation contractor with the Workplace Safety and Health Division
- notified the Workplace Safety and Health Division of your excavation and obtained a serial number for your excavation
- obtained clearances from underground facilities (ex: Manitoba Hydro)
- obtained engineering approvals where required
- provided appropriate training for all workers involved in the excavation work

### Becoming a Registered Excavation Contractor

All employers are required to notify the Workplace Safety and Health Division and obtain a registration number before beginning excavation work. Once this number is obtained, the employer is considered a registered excavation contractor. The following information must be provided to become a registered excavation contractor:

- company (legal) name
- address
- contact name
- if you have ever had a registration revoked
- type of excavation work to be engaged in

Information provided to you by the Workplace Safety and Health Division will include:

- a copy of your registered information (including the information you provided along with your registration number)
- basic legislative requirements relating to excavation and confined entry work
- other specific legislation requested by you
- instructions on how to obtain a serial number for excavations as well as the forms to use

If an employer is not performing excavation work safely, a safety and health officer may revoke the registration. At that point, the employer cannot do any more excavation work. If the registration is revoked, an employer may re-apply for registration, but must prove to the satisfaction of a safety and health officer that the requirements of Part 26 of the Workplace Safety and Health Regulation relating to excavations are understood and excavation work will be done safely.

If you plan to perform excavation work and are not a registered excavation contractor, call the Workplace Safety and Health Division and register your company.

## **Obtaining a Serial Number for Excavations from the Workplace Safety and Health Division**

Every contractor who intends to make an excavation in excess of 1.5 metres (five feet) in which a worker may enter must notify the Workplace Safety and Health Division not more than 48 hours before the day that excavation work is scheduled to begin. The Workplace Safety and Health Division will assign a serial number to the excavation. The contractor must supply the following information to the Workplace Safety and Health Division prior to a serial number being assigned to the excavation:

- name and address of the owner of the land where the proposed excavation is to be made
- name and address of the employer planning to excavate along with their excavation contractor's registration number
- location of the excavation
- date the work is to start and the proposed completion date
- description of the proposed depth, length and width of the excavation
- description of the planned method of shoring, including the type of materials to be used
- verification that the appropriate underground facilities have been notified and that the locations of any pipes, conduits or previous excavations in or near the proposed site have been determined
- name of the person who will be supervising the excavation

To obtain a serial number for your excavation, call the Workplace Safety and Health Division and provide your information over the telephone. You may also ask the division to provide you with a form that you can complete and return by fax or e-mail. Once the information is recorded and a serial number is assigned to the excavation, verification will be given back to the employer by the division.

## **Obtaining Clearances from Underground Facilities**

Exposure to underground facilities is a common hazard for workers in or near excavation work. Serious incidents have occurred when excavators have made contact with a gas or energized electrical line, causing fires, explosions and injuries. Therefore, excavation work cannot begin until all owners of underground facilities have been notified and the accurate locations of all underground facilities have been determined.

If damage to a pipe, cable or other underground facility occurs once the excavation has started, the employer must immediately advise the owner of the underground facility. No further excavation work should be done until the owner of the underground facility has completed an on-site inspection. The workers must be evacuated from the work area if an energized cable is exposed or dangerous fluids or gases are released.

## Requirement for Engineering Approvals

Employers must use the services of a professional engineer to design support structures where a worker is required to enter an open excavation or trench under the following circumstances:

- the open excavation exceeds three metres (10 feet) in depth, or the trench exceeds 4.5 metres (15 feet) in depth.
- a safety and health officer is of the opinion that a temporary support structure may create a risk to the safety and health of a worker, or there is a change in the ground stability for which the support structure was originally installed.
- where a worker is required to enter any deep foundation excavation, including caissons and piles, a professional engineer must provide approval on the methods of entry and exit as well as the equipment and methods to be used for hoisting.
- the excavation may affect the structural integrity of a nearby building, foundation, utility pole or other structure.
- an employer installs re-shoring.

Trench cages to be used or stacked, must be designed and certified by a professional engineer.

When employers are required to obtain design specifications from a professional engineer, the specifications must include:

- design and specifications of the support structure, including the type and grade of materials used in its construction
- loads and types of soil conditions the structure is designed for
- installation, use and dismantling instructions

Employers must also ensure that a temporary support structure, designed by a professional engineer, is inspected and certified after installation is complete.

## Training for Workers

Employers must provide workers with information and training on:

- workplace hazards that they may encounter
- safe work procedures developed to address those hazards
- devices or personal protective equipment required and provided for their use

Training needs to take place:

- before workers perform work at the workplace
- before workers perform a different work activity than they were originally trained to perform
- before workers are moved to another area of the workplace or a different workplace that has different facilities, procedures or hazards

Training of workers working near excavation sites must include:

- legal requirements at the excavation site, requirement for control measures if

the excavation is over 1.5 meters (five feet) deep, engineering approvals and rights and responsibilities of workers, employers and supervisors, etc.

- specific excavation site hazards. This includes the common hazards listed in this guideline and site specific or work specific hazards that the workers may be exposed to.
- control measures put in place to protect workers against the hazards they may be exposed to. This includes temporary support structures, personal protective equipment required, safe work procedures and any other controls that have been put in place.
- Any other legislative requirements including, but not limited to, first aid requirements on site, emergency situation procedures, working alone requirements and confined space requirements.



# LEGAL REQUIREMENTS AT EXCAVATION SITES

Part 26 of the Workplace Safety and Health Regulation contains specific legal requirements to follow before excavation work can begin.

## General requirements include:

### Registration

- contractors planning to perform excavation work must register as excavation contractors with the Workplace Safety and Health Division.

### Notification

- excavation that will be more than 1.5 metres (five feet) deep must receive a serial number from the Workplace Safety and Health Division.

### Supervision

- a competent supervisor must be on site at all times when a worker is in an excavation or excavation work is being done.
- a competent person must be at the surface of any excavation more than 1.5 metres (five feet) deep where a worker is required to enter.

### Identification and Control of Hazards

- workers must be equipped with a full body harness and lifeline if there is a risk of flooding in the excavation.
- tests must be done to ensure that workers do not enter an excavation where a hazardous atmosphere exists.
- excavated material must be placed at a minimum of one metre from the edge of an excavation.
- excavations must be guarded so that materials, workers or pedestrians do not fall into the excavation.
- walkways over an excavation must be constructed so that they have appropriate guardrails to prevent users from falling.
- a ladder, stairway or ramp must be in place for entering and exiting an excavation more than 1.5 metres (five feet) deep. Ladders must extend more than one metre (three feet) from the top of the excavation and must not be located more than three metres (10 feet) from the worker inside the excavation.

## Support Structures

- appropriate temporary support structures must be in place in excavations that are more than 1.5 metres (five feet) deep unless the excavation is in solid rock or the walls of the excavation have been adequately sloped.

Refer to Part 26 of the Workplace Safety and Health Regulation relating to Excavations and Tunnels for specific requirements.

## Other Legislation

Employers planning to perform excavation work must be familiar with the requirements of the Workplace Safety and Health Act, and all parts of the workplace safety and health regulation that apply to the excavation site.

Employers should be familiar with the following parts of the Workplace Safety and Health Regulation:

- Part 2 General Duties
- Part 5 First Aid
- Part 12 Personal Protective Equipment
- Part 13 Hearing and Noise Control
- Part 14 Fall Protection
- Part 15 Confined Spaces
- Part 22 Powered Mobile Equipment
- Part 24 Pile Driving Equipment

## Quick Reference for Soil Categories

<b>Soil Categories (Specific to Manitoba)</b>				
<b>1(a)</b>	<b>1(b)</b>	<b>2</b>	<b>3(a)</b>	<b>3(b)</b>
<b>Cohesive soils</b> of firm to stiff consistency that are <b>unfissured</b> .	<b>Cohesive soils</b> of firm to stiff consistency that are <b>fissured</b> .	<b>Cohesive soils</b> of <b>soft consistency</b> and <b>non cohesive silt</b> soils.	<b>Cohesionless soils</b> of <b>loose to medium dense</b> consistencies.	<b>Cohesionless soils</b> of <b>dense to very dense</b> consistencies.

## SOIL PROPERTIES

Soil Categories specific to Manitoba are classified as follows:

- **Category 1** – Cohesive soils of firm to stiff consistency that are fissured (**Category 1b**) or unfissured (**Category 1a**). These soils are generally of medium to high plasticity but may also include glacial clay tills of low to medium plasticity. These soils usually have low moisture content and most often occur above the water table.



- **Category 2** – Cohesive soils of soft consistency and non cohesive silt soils. The cohesive soils can be of medium to high plasticity while the silt soils are of non to low plasticity. These soils typically have high moisture contents and will tend to fill voids left between the excavation walls and shoring.

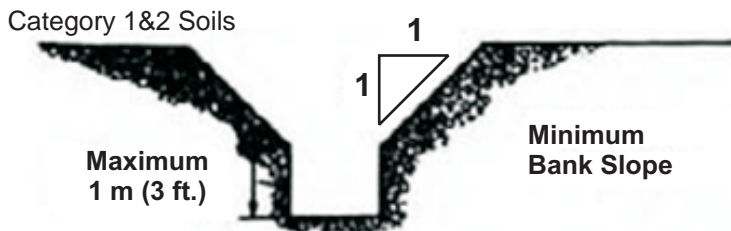

- **Category 3** – Cohesionless soils of loose to medium dense (**Category 3a**) and dense to very dense (**Category 3b**) consistencies. The Category 3a soils are generally easy to excavate by hand and are easily disturbed by construction equipment, particularly when they are at or near the water table or become saturated. Category 3b soils are generally not easy to excavate by hand and are not easily disturbed by construction equipment, except if they are at or near the water table or become saturated.



## Manitoba Soil Types

The following soil types are generally found in Manitoba:

### Cohesive Soils

- Silty clay – soil of medium to high plasticity of primarily lacustrine origin. The silty clay can range from soft to hard depending on the moisture content and is usually brown in the upper six to 10 metres and grey below indicating the extent of previous oxidation and weathering. Typically, the upper three metres of lacustrine clay is weathered, fissured and nuggety. Silty clay is primarily found within the area formerly occupied by post glacial Lake Agassiz which, in Manitoba, includes the Red River Valley and most of northern Manitoba to approximately the Tadoule Lake area. Generally, unfissured silty clay will have a good short-term performance in excavations but the stability will decrease the longer an excavation is left open. The unfissured silty clay will most often collapse in rotational manner as shown in Collapse Type 4 (page 23). Fissured silty clays will generally have poor performance in excavations and will often fail as in a narrow side wall shear as shown in Collapse Type 2 (page 22). For both types of silty clay (fissured and unfissured), introduction of excessive moisture will often result in relatively unstable excavation conditions.
- Alluvial Clay – soil of medium plasticity, although plasticity can range from low to high. Alluvial clay can vary greatly in grain size distribution and consistency, but generally, the major constituent of this soil type is silt, followed by clay and then sand. Alluvial clay can range from very soft to stiff, depending on moisture content. In a dry state, the soil may often appear to be cohesionless, while in a wet state, alluvial clay is often very soft and subject to sloughing. Alluvial clays are most commonly found along inside bends in riverbanks in the Red River Valley and in southern and western Manitoba. In a dry state, these soils perform relatively poorly in excavations, because they tend to fail in a narrow side wall shear, as shown in Collapse Type 2 (page 22), soon after an excavation has been completed. In wet or saturated state, these soils will typically slough during the excavation process as shown in Collapse Type 3 (page 23) and have little or no strength.
- Low to medium plastic clay (locally known as silt) – soil of low to medium plasticity that is generally light yellowish brown (tan) in color and commonly referred to as silt. Within the Red River Valley, the major constituent of this soil type is silt, typically followed by clay and fine grained sand. The structure of this soil generally consists of thin laminations and seams or inclusions of high plastic clay sandwiched between thicker layers of silt and fine sand. When the clay laminations are combined with the thicker layers of silt or sand and tested, the results most often indicate a soil of low to medium plasticity (CL to CI), although it can be non-plastic in some locations. The low to medium plastic clay can range from very soft to firm, depending on moisture

content. In a dry state, the silt is often soft to firm, but becomes soft to very soft as its natural moisture content increases. In a saturated state, the silt has very little strength, is subject to significant sloughing, as seen in Collapse Type 3 (page 23), and is generally unstable in a vertical cut.

- Glacial clay till – heterogeneous mixture of boulders, cobbles, gravel, sand, silt and clay, generally of low to medium plasticity. Glacial clay till can vary from soft to hard, primarily dependent on moisture content and deposition characteristics. Glacial clay till is predominantly found in western Manitoba, and is often weathered and fissured near the ground surface. Generally, stiff to hard glacial clay till will perform relatively well in vertical cuts over a short term. In a saturated or wet state, glacial clay till will tend to slough, as seen in Collapse Type 3 (page 23), and be unstable in a vertical excavation.

## Cohesionless Soils

- Silt – soil that is non-plastic to low plastic. Silt ranges from loose to extremely dense depending on moisture content and deposition characteristics. Silt is seldom encountered in a pure state, but normally has a significant fine sand component and occasionally a trace of some clay. Silt can be found throughout Manitoba as either a relatively uniform or a discontinuous deposit within a given area. In a dry state, silt is relatively unstable in vertical cuts and requires sloped or shored excavation walls. Silt often collapses in a side wall shear manner, as seen in Collapse Type 2 (page 22). When saturated, the silt exhibits a dilative behaviour; it is very unstable in vertical cuts and unstable in steeply sloped excavations, as seen in Collapse Type 3 (page 23), unless the soil is dewatered.
- Sand – sand can range greatly in grain size and density, and is often poorly graded (sorted). Sporadic deposits of sand occur in most regions of Manitoba, although they are more prevalent in the Red River Valley with the exception of the Birds Hill area. In a dry state, sand is unstable in vertical cuts and requires sloped excavation walls. Typically, saturated sand exhibits a dilative behaviour (fine grained sand), unstable with respect to excavations, and is subject to sloughing, as seen in Collapse Type 3 (page 23).
- Gravel – like sand, gravel can have a wide range of grain size distribution and density. Like sand, sporadic deposits of gravel are found in most regions of Manitoba although they are more prevalent in western, southeastern, and northern Manitoba and less prevalent in the Red River Valley, with the exception of the Birds Hill area. In a dry state, gravel is generally more stable than sand (although still somewhat unstable) in vertical cuts, but still requires sloped excavation walls. Typically, on saturation, gravel becomes unstable (although less so than other cohesionless soils) with respect to excavation, and is subject to sloughing, as seen in Collapse Type 3 (page 23).
- Glacial silt till – soil that is non-plastic to low plastic. Glacial silt till is a heterogeneous mixture of boulders, cobbles, gravel, sand, silt and clay. Generally, within the boundaries of post-glacial Lake Agassiz, two types of glacial silt till can be present, namely ablation (water-laid) till and basal (glacier-laid) till. The ablation tills (locally known as “putty” till) are typically wet and loose (soft to very soft). The basal tills are typically dense to very dense and often have a cemented structure. Generally, the ablation tills are unstable with respect to excavations, while the basal tills are relatively stable unless they become saturated, as seen in Collapse Type 3 (page 23).
- Peat and organic soils – soils that are typically encountered in low areas (ex: in marshy or poorly drained areas) and are often wet and loose (soft). Peat soils are often fibrous at the top of the deposit and gradually change to less fibrous (amorphous) peat as a function of depth and level of decomposition. Peats and organic soils are generally found in eastern and northern Manitoba

in areas dominated by Precambrian shield geology (ex: poorly drained areas). Generally, peat and organic soils are very unstable with respect to excavations, as seen in Collapse Type 3 (page 23), because they have relatively little strength in a natural state and often have very high moisture contents.

- Fill – fill can be a single soil type or a mixture of various soil types such as clay, sand, gravel, organic soils, etc. and may even contain non-soil materials such as demolition rubble or wood. It can vary widely in consistency, but is often softer or looser than the surrounding native soil, and has a greater likelihood of sloughing when encountered in excavations. In particular, it cannot be relied upon to be uniform, even over short vertical and horizontal distances, and may collapse in any one of several different modes, depending on its makeup.

## **Bedrock**

- Sedimentary – sedimentary bedrock (primarily limestone and shale) is typically located along the southern two-thirds of the Hudson Bay and in western and west central Manitoba. The limestone and shale bedrocks are typically highly weathered and fractured when at or near the natural ground surface, but often become less fractured and more intact with depth. The shale bedrocks are generally considered to be soft rock while limestone can vary from soft to hard. Generally, limestone bedrock is stable to very stable with respect to excavations or rock cuts. Similarly, shale bedrock can also be stable to very stable but, in instances where the shale is fractured or contains existing failure planes, the shale can perform poorly. Further complicating the performance of shale bedrock is the presence of low strength bentonite laminations or seams, which will usually adversely affect on the stability of rock cuts. The presence of a relatively high groundwater table can also adversely affect the stability of shale bedrock in rock cuts.
- Igneous – igneous bedrock is located in eastern, east central, and northern Manitoba. The igneous bedrock is comprised primarily of granite and granitoids. Generally, the igneous bedrock is weathered and fractured when occurring at or near the natural ground surface, but typically becomes less fractured and more intact with depth. This bedrock is generally considered to be hard rock. Generally, igneous bedrock is stable to very stable with respect to rock cuts.



## Types of Soil Collapse

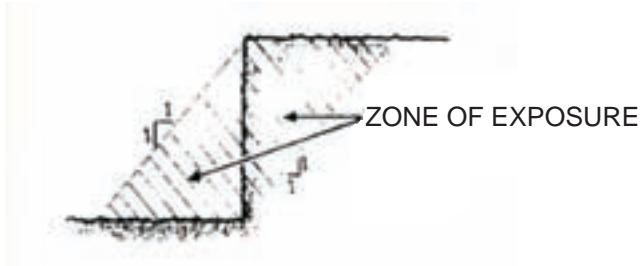

### General Zone of Exposure

(the area where workers are exposed to mass soil or rock movement)

### Collapse Type 1

Spoil pile slide – improper excavating procedures occur when the excavated material is not placed far enough away from the edge of the excavation. The recommended minimum distance for location of excavated soil (spoil) from the edge of the excavation is equal to or greater than the excavation depth. However, the minimum permissible distance of spoil from the edge of the excavation is 0.6 metres for every one metre of excavation depth.

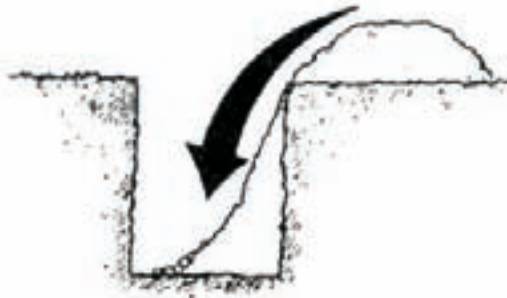

### Collapse Type 2

Side wall shear – common to fissured or desiccated clay-type or alluvial soils that are exposed to drying.



### Collapse Type 3

Slough-in (cave-in) – common to previously excavated material, fill, sand, silt and sand mix and gravel mix where the water table is above the base of excavation, or where soils are organic or peat.



### Collapse Type 4

Rotation – common in clay-type soils when excavation walls are too steep, or when moisture content increases rapidly.

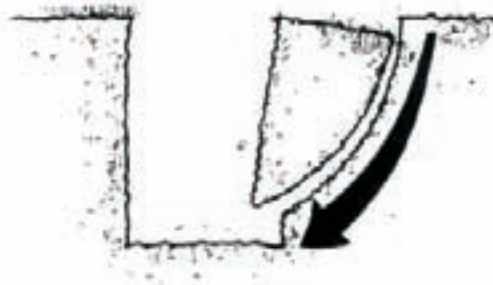

# EXCAVATIONS

A support structure (shoring) is required, or the excavation walls must be sloped at an appropriate angle, before a worker enters an excavation considered to be:

- A **trench excavation** exceeding 1.5 metres (five feet) in depth.

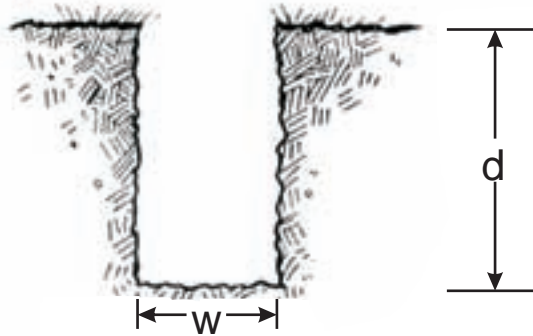

Trench ( $d > w$ )  
Excavation

- An **open excavation** exceeding 1.5 metres (five feet) in depth. An open excavation is any excavation that does not meet the criteria of being a trench, shaft, tunnel or caisson.

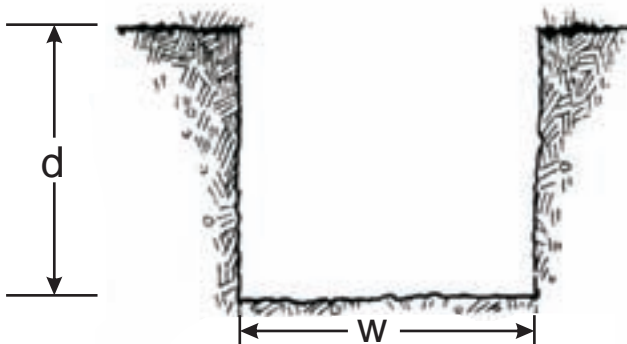

Open ( $w > d$ )  
Excavation

The shoring (temporary support structure) must be designed to withstand all external forces that may be caused by:

- soil pressures
- water pressures
- nearby structures
- additional loadings and vibrations (heavy equipment, traffic, temporary piled materials near the excavation, etc.)

Unless approved by a professional engineer, shoring must be installed so that it is in firm contact with the walls of the excavation. This may require backfilling of voids between the walls of an excavation and the shoring.

Excavations required below the water table in cohesionless soils (ex: wet sands) may only be performed where an appropriate dewatering system has been installed. The ground water elevation should be lowered and maintained at a minimum of 0.6 metres (two feet) below the base of the excavation.

Temporary structures designed by a professional engineer must be inspected and certified by the same professional engineer to verify that the temporary structure has been installed according to the design.

Excavation contractors must notify the Workplace Safety and Health Division about any excavation wall failures.

## Sloped Excavations

**Fully sloped (Vee'd) excavations** – besides use of a shoring support structure, a safe method to protect workers in an excavation is to slope the walls of the excavations at a grade of 1H:1V (45 degrees) or flatter. The 45-degree slope is required no matter what type of soil conditions exist.

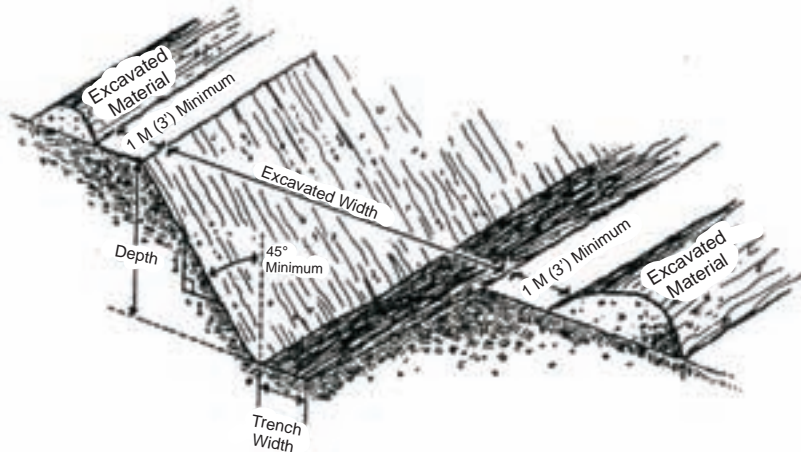

**Combination slope and vertical face** – A combination 1H:1V (45-degree) slope and vertical face may be used in some soils, as long as the vertical face does not exceed one metre (three feet), the overall depth of the excavation is not greater than five metres (16 feet), and where the soil is not subject to sloughing when saturated (ex: silt, sand, alluvial clay).

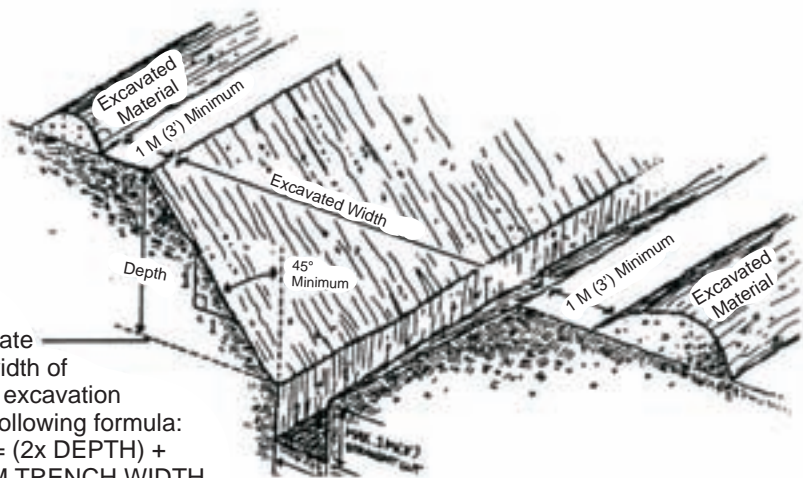

To calculate overall width of a sloped excavation use the following formula:  
$$\text{WIDTH} = (2 \times \text{DEPTH}) + \text{BOTTOM TRENCH WIDTH}$$

## Temporary Support Structures/Shoring

**Shoring materials** – the majority of wood shoring used in trenches in Manitoba is made of full dimension wood planks and timbers. Spruce lumber is also acceptable as shoring material if it meets the shoring requirements listed in the Shoring Table (page 28). The lumber must be construction grade SPF No. 2 or better. Plywood used as sheathing material in loose soils must be a minimum of 20 millimetres (three-quarters inch) thick. Steel trench jacks may be used as struts if they are equivalent in strength to the wood struts specified in the shoring tables. The longer dimension of the trench jack foot must be located

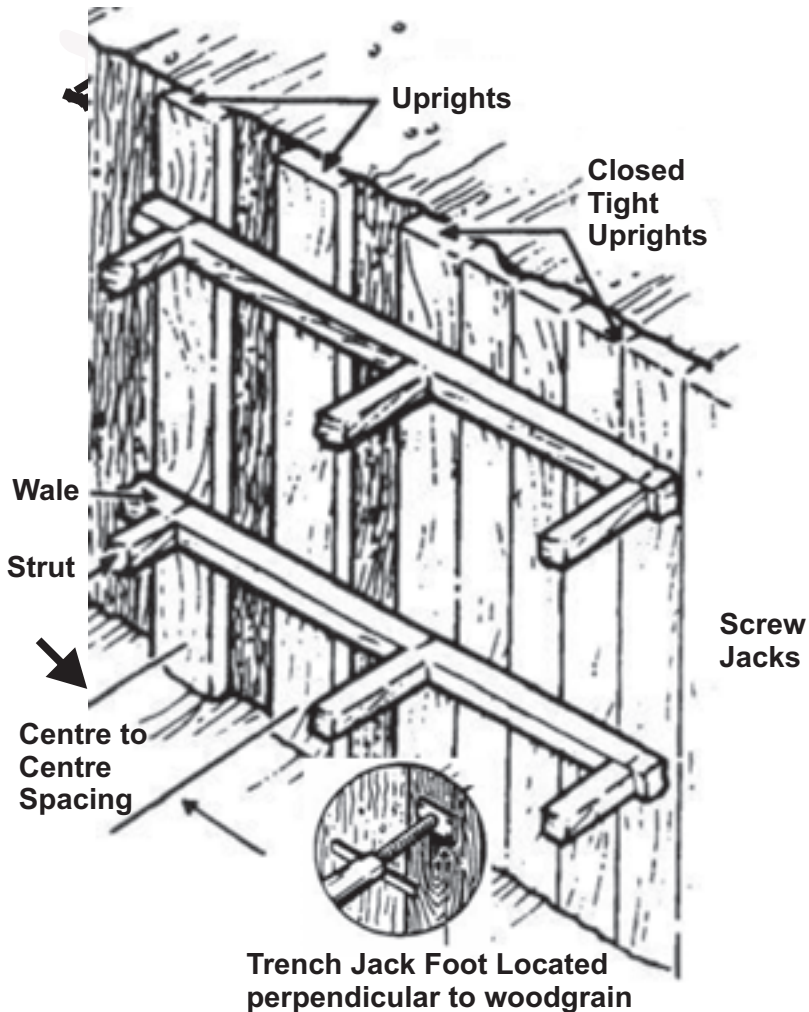

# Shoring Table

Category	DEPTH		UPRIGHTS (Vertical Members)				STRINGERS / WALES (Horizontal Members)*				CROSS-BRACES, STRUTS (Horizontal)*				
	(ft)	(m)	Member minimum dimensions (millimetres)	minimum 2-span continuous maximum spacing horizontally		Member minimum dimensions (millimetres)	(ft)	minimum 2-span continuous maximum spacing vertically		Member minimum dimensions (millimetres)		maximum spacing vertically (to match Stringers / Wales)		maximum spacing horizontally along Stringers / Wales	
				(ft)	(mm)			(ft)	(mm)	Width of Trench		(ft)	(mm)	(ft)	(mm)
Category 1a) - stiff clays, & stiff --> hard clay tills, & stiff fissured clays	5	1.5								less than 1.8 metres	1.8 metres to 3.7 metres				
	10	3.0	38 x 235 (2x10s)	1.26	384	89 x 140 (4x6s)	4.0	1200	89 x 89 (4x4s)	140 x 140 (6x6s)	4.0	1200	4.22	1291	
	15	4.6	38 x 235 (2x10s)	1.13	344	191 x 191 (8x8s)	3.0	915	89 x 89 (4x4s)	140 x 140 (6x6s)	3.0	915	4.82	1475	
Category 1b) - stiff fissured soils, & stiff clay fills	5	1.5								less than 1.8 metres	1.8 metres to 3.7 metres				
	10	3.0	89 x 140 (4x6s)	2.25	686	89 x 140 (4x6s)	4.0	1200	89 x 89 (4x4s)	140 x 140 (6x6s)	4.0	1200	2.60	796	
	15	4.6	89 x 140 (4x6s)	1.85	564	191 x 191 (8x8s)	3.0	915	89 x 89 (4x4s)	140 x 140 (6x6s)	3.0	915	3.07	939	
Category 2 - soft cohesive soils, & stiff --> wet/loose silt soils	5	1.5								less than 1.8 metres	1.8 metres to 3.7 metres				
	10	3.0	38 x 235 (2x10s)	0.75	229	89 x 140 (4x6s)	4.0	1200	89 x 89 (4x4s)	140 x 140 (6x6s)	4.0	1200	3.00	918	
	15	4.6	89 x 140 (4x6s)	1.50	457	191 x 191 (8x8s)	3.0	915	89 x 89 (4x4s)	140 x 140 (6x6s)	3.0	915	2.90	887	
Category 3a) - Cohesionless: loose --> medium dense soils	5	1.5								less than 1.8 metres	1.8 metres to 3.7 metres				
	10	3.0	38 x 235 (2x10s)	1.07	326	89 x 140 (4x6s)	4.0	1200	89 x 89 (4x4s)	140 x 140 (6x6s)	4.0	1200	3.90	1193	
	15	4.6	38 x 235 (2x10s)	0.96	293	191 x 191 (8x8s)	3.0	915	89 x 89 (4x4s)	140 x 140 (6x6s)	3.0	915	4.44	1359	
Category 3b) - Cohesionless: dense to very dense soils	5	1.5								less than 1.8 metres	1.8 metres to 3.7 metres				
	10	3.0	38 x 235 (2x10s)	1.51	460	89 x 140 (4x6s)	4.0	1200	89 x 89 (4x4s)	140 x 140 (6x6s)	4.0	1200	4.62	1414	
	15	4.6	38 x 235 (2x10s)	1.36	415	191 x 191 (8x8s)	3.0	915	89 x 89 (4x4s)	140 x 140 (6x6s)	3.0	915	5.28	1616	
*Notes for Tables:	1. 38mmx235mm (2x10s) except as noted above, S.P.F No. 2 & better		2. Design based on O86.1-2001 Wood Design Manual; all "uprights" (vertical shoring) to be minimum 2-span continuous (cantilevers not to be included as "spans"). All shoring assumed to have members orientated for weak-axis bending				3. All members to be graded lumber meeting S.P.F. No. 2 or better.				4. All spacings shown are centre-to-centre of members.				

## Installation of Shoring

When installing shoring within a trench type excavation, appropriate procedures must be followed to provide for a safe excavation.

Uprights, struts (screw jacks), wales and plywood must be installed according to the shoring table that is based on the soil conditions, depth and width of the trench and excavation.

When installing shoring, the bucket of the excavation machine must be placed in the trench directly in front of the shoring being installed. The bucket will serve as additional protection if a cave-in occurs.

An appropriate ladder must be provided in a trench or open excavation. The ladder must extend at least one metre (three feet) above ground level at the surface of the excavation and be within three metres (10 feet) of a worker's working position inside the excavation.

Shoring struts/jacks must be installed from the top down. It is important that the top (first) strut/jack is placed approximately 0.5 metres (18 inches) below the surface, and the second strut/jack is placed according to the shoring table. Installing the first and second strut/jacks is necessary to support the vertical uprights that stabilize the excavation walls.

When plywood is used as sheathing material, the jacks must be placed on the uprights that support the plywood. Jacks or struts must never be installed directly on to the plywood. If the walls move, the jack or strut could push through the plywood.

Once the worker has at least two struts/jacks placed on each set of uprights, the worker can proceed to install the bottom strut/jack. There must never be less than two struts/jacks used on each set of shoring.

This procedure must be followed with each set of shoring. This method protects the worker with the bucket of the digging machine and the shoring already installed.

All components must be used as specified in the shoring table at all times.



## Proper Procedures for Installing Shoring

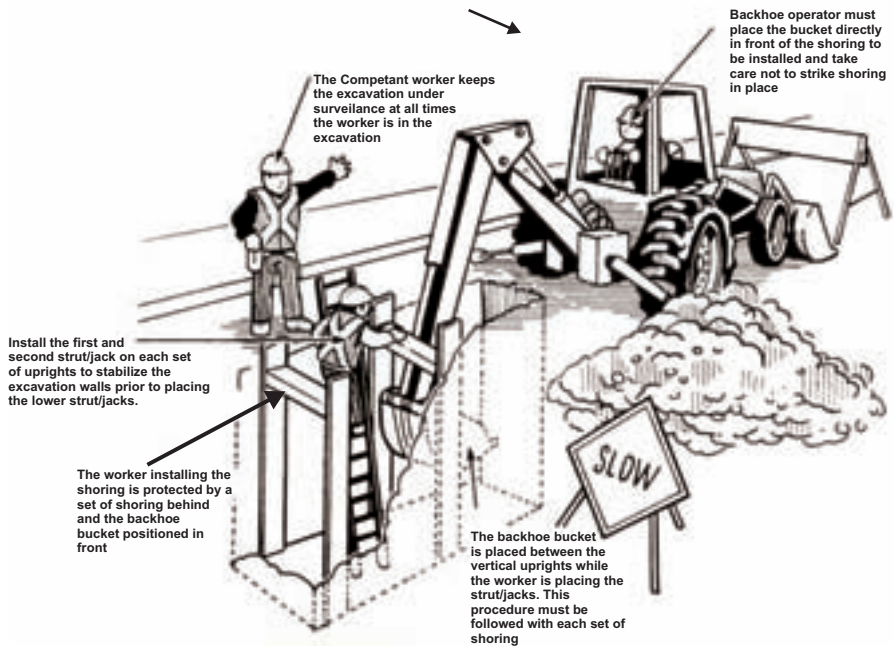
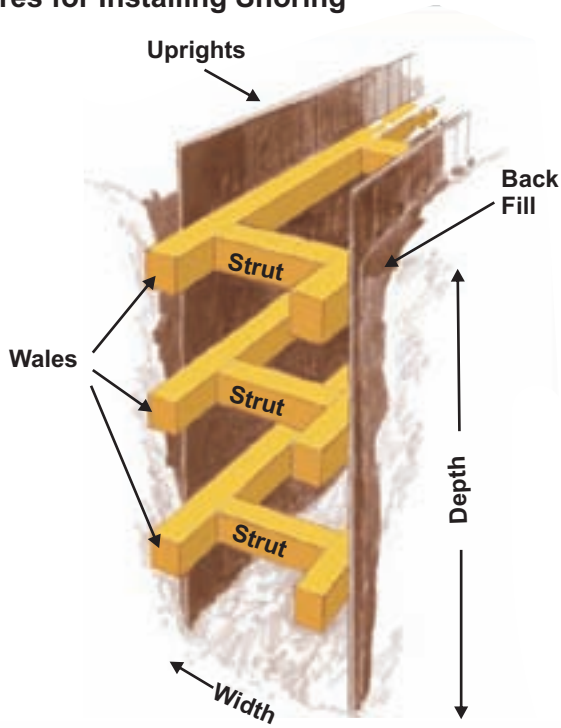

## Shoring Removal

The procedure to remove shoring is the opposite of the procedure for installation. Struts are removed in the opposite order that they were installed. There must never be less than two sets of uprights in place. Workers removing the shoring must always stay between the shoring in place for protection.

Prior to removing a strut or jack, the trench should be backfilled to a depth equal to the elevation of the strut or jack being removed. This backfilling procedure shall be performed prior to removal of each strut or jack.

### Sequence for the Installation and Removal of Shoring

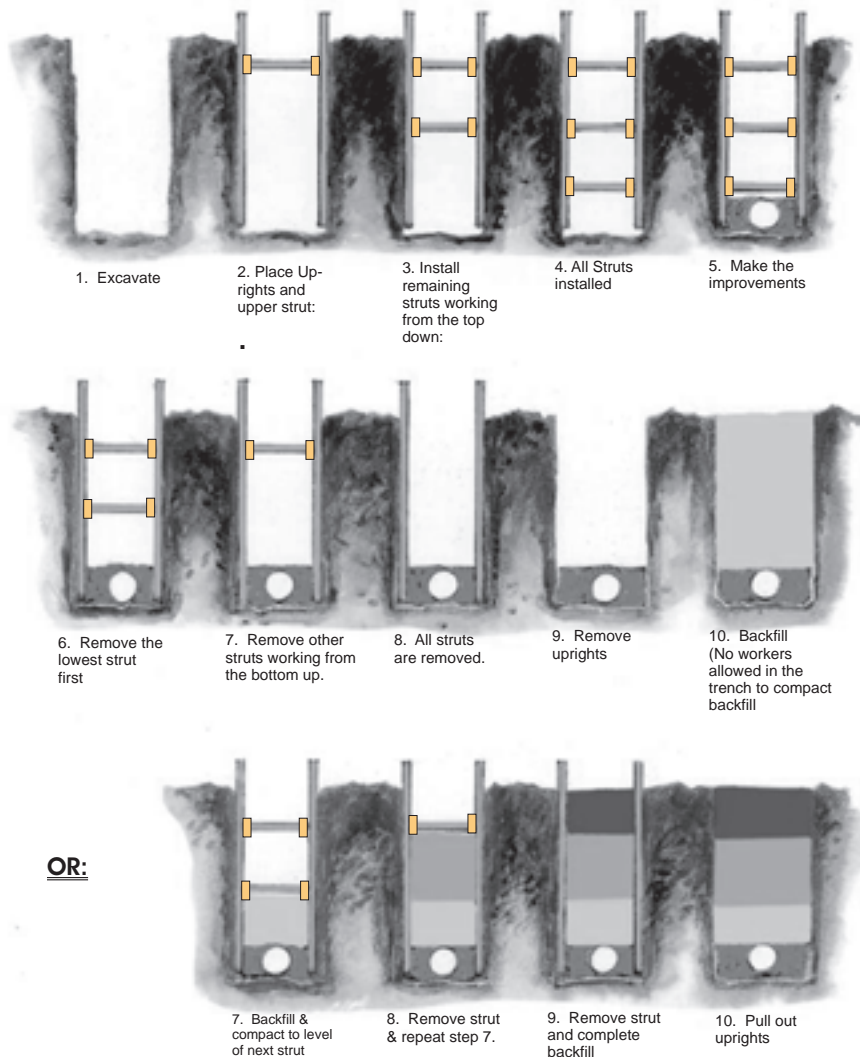

## Prefabricated Support Systems (Trench Cages)

A trench cage is a type of prefabricated support system consisting of a self-contained steel structure that is placed in an excavation before construction begins or workers enter. This support system is designed to withstand the soil pressures and protect workers from sloughing or collapse of the excavation walls.

Trench cages must be designed by a professional engineer and constructed, inspected, and maintained according to appropriate engineering specifications.

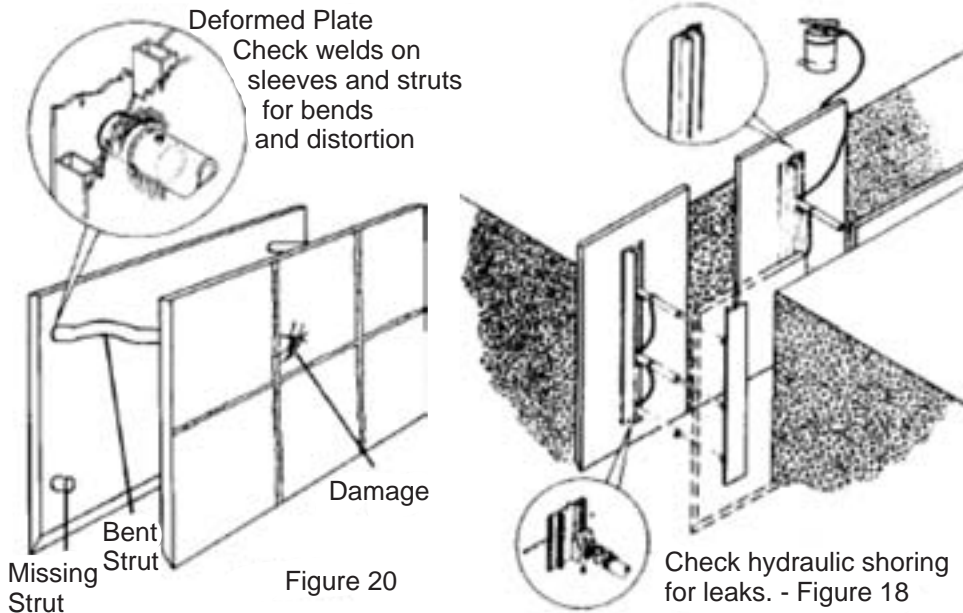

Trench cage design is normally based on an earth pressure of 3.6 kPa (75 pounds per square foot) and the depth of an excavation.

When trench cages must be stacked in deeper excavations, the procedure for stacking, as well as the connections between trench cages, must be approved by or designed by a professional engineer. The connections between the trench cages must be designed to transmit loading conditions between cages.

Trench cages must have continuous sides and extend at least 300 millimetres (12 inches) above the vertical wall of the excavation.

Hoisting hook-up and drag points on trench cages must be designed and approved by a professional structural engineer. Hook-up and drag points are used to install the trench cage in an excavation, reposition it and remove it. Construction or other workers should not be inside a trench cage being repositioned by dragging.

## WORKERS ARE NOT TO WORK OUTSIDE THE PROTECTION OF THE TRENCH CAGE!

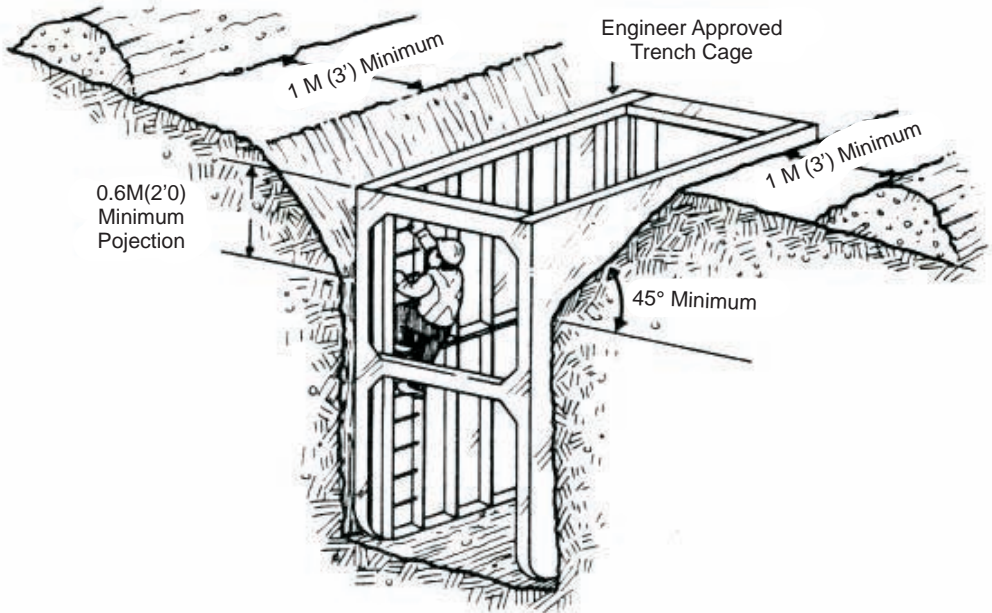

### Hydraulic/Pneumatic Support Systems

Hydraulic and pneumatic support systems are advantageous because workers do not have to enter the excavation to put the supports in place. These systems are often made of lighter materials like aluminum and can be handled easily. Care must be taken to ensure that the systems are properly maintained when in use.

Hydraulic and pneumatic support systems must be certified by a professional structural engineer to meet the requirements specified in Table 1 for the particular soil conditions.

## Additional Considerations for Open Excavations

Open excavations (example basement or foundation excavations) that exceed 1.5 meters (five feet) in depth require: excavation walls to be fully sloped at a minimum gradient of 1H:1V; partially sloped at 1H:1V combined with vertical slopes for the bottom one meter (three feet) of the excavation; or a shoring system designed and installed.

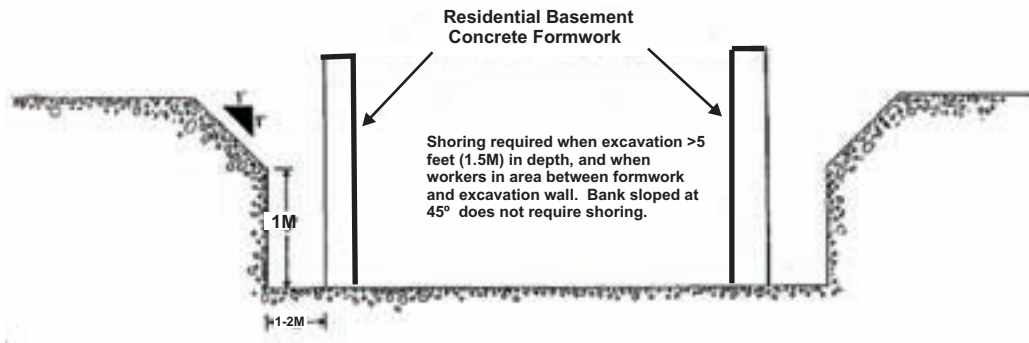
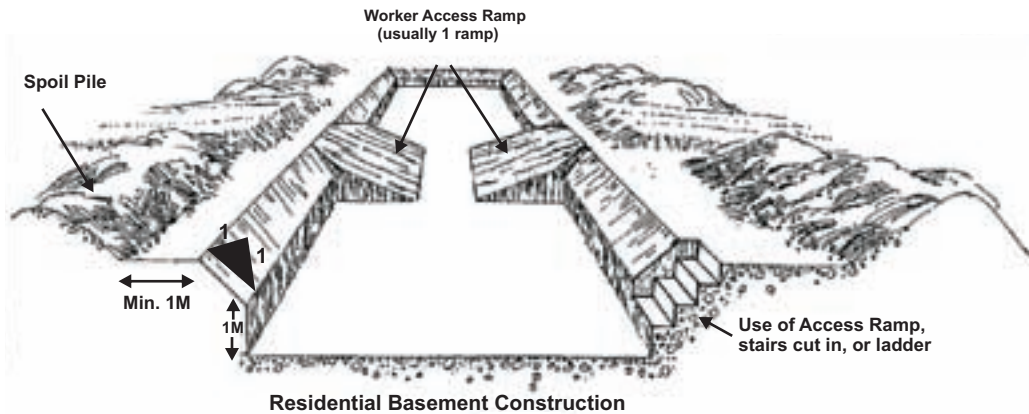

A shoring system for an open excavation greater than three metres must be designed by a professional structural engineer. If the open excavation is more than 1.5 metres deep, but less than 4.5 metres, the professional engineer must follow the shoring table in the regulation. If it is determined a shoring system, made of components other than those in the shoring table, is required for an excavation less than 4.5 metres deep, that shoring system must be designed and certified by a professional engineer. Typical structures consist of heavy wood lagging supported by steel I-beams properly installed into the foundation. The engineering specifications must include complete details on the correct shoring installation procedures as well as on-going inspection and monitoring criteria to ensure the shoring is maintained in safe condition.

**BE AWARE!** An open excavation may become a trench excavation as the project proceeds.

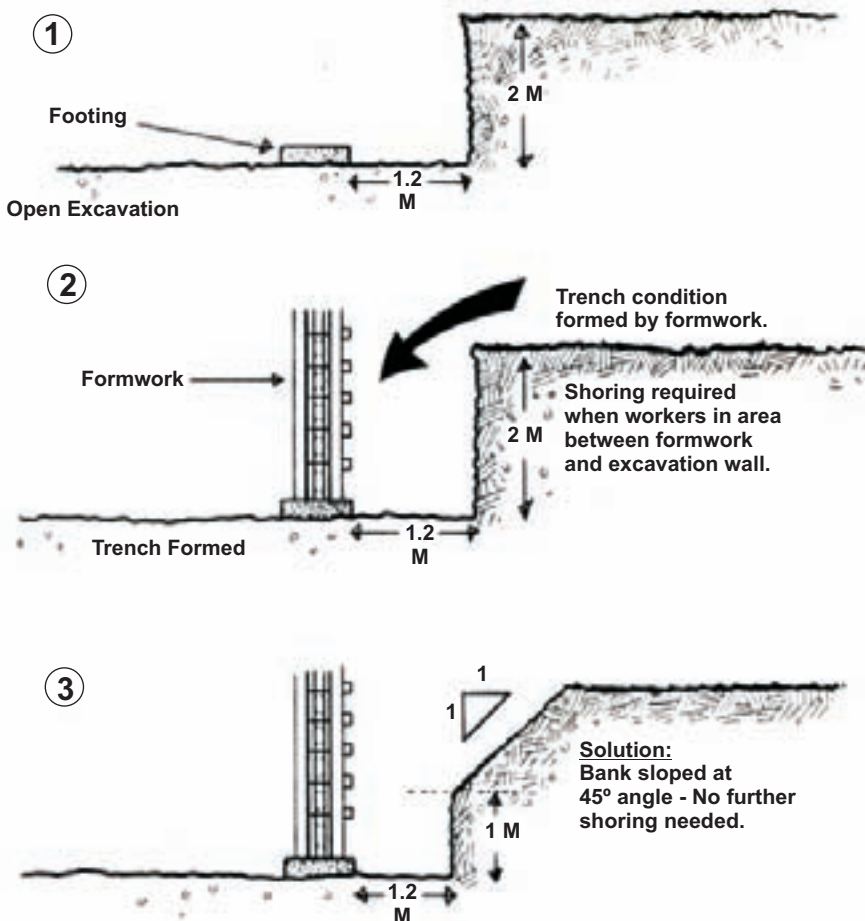

## SHAFT AND TUNNEL EXCAVATIONS

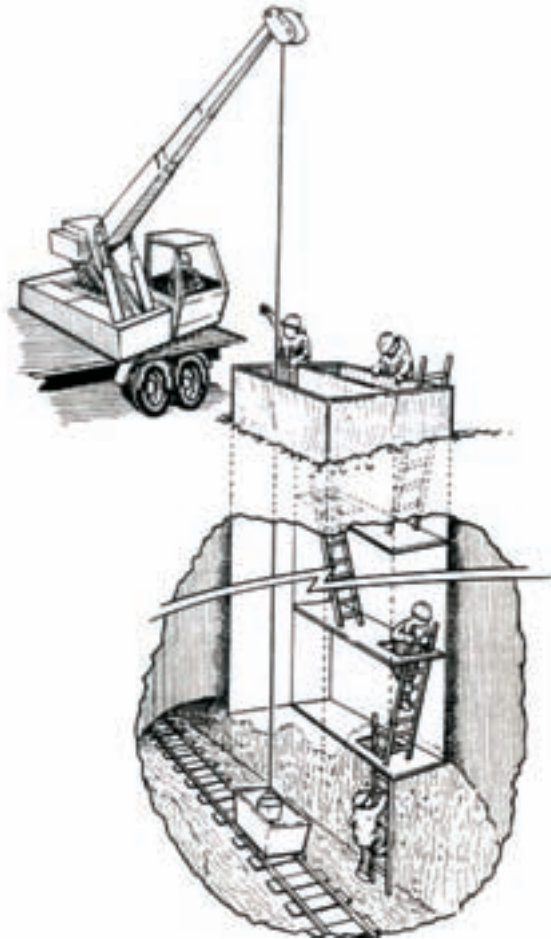

Shaft and tunnel excavations are primarily used in sewer, water and other utility work, and include procedures such as vertical circular shafts, hand-tunneling operations and fully mechanized excavating systems (moles).

All requirements outlined in the previous sections of this guideline apply to shaft and tunnel excavations. All support structures used for shaft and tunnel excavations must be designed and certified by a professional engineer. The professional engineer's design specifications must be kept on site and be readily available to worker on request.

Additional hazards to be addressed because of the nature of the shaft and tunnel excavations, include:

## Housekeeping

Good housekeeping helps to prevent injuries near excavation sites. Shaft and tunnel excavations need particular attention. Part 26 of the Workplace Safety and Health Regulation (relating to excavations and tunnels) addresses the need to keep work areas free of mud and debris, including access landings, the bottom of the shaft or tunnel and other work areas. Scrap materials inside the shaft or tunnel must be removed daily and must not be allowed to accumulate.

## Falls

Fall hazards are common at excavation sites. To control this hazard in shaft and tunnel excavations, guardrails must be installed at shaft openings. Toe boards must also be in place to prevent any equipment or debris from falling into the shaft or tunnel excavation. Access ways to shaft or tunnel excavations must be covered when not in use to prevent falls.

## Access/Egress

Three hazards are introduced when dealing with access and egress from a shaft or tunnel excavation. The first hazard deals with personnel entering and exiting the shaft or tunnel. The second hazard deals with equipment entering or exiting the shaft or tunnel. The third deals with removing excavated material from the shaft or tunnel.

Specific requirements must be followed when workers enter or exit a shaft or tunnel excavation. The access way provided must be the full depth of the shaft that the person is required or permitted to enter. This will ensure a worker is able to exit the excavation at any time from any work area. The access way must be completely separate from a hoist way that is or could be transporting materials or equipment. This prevents the risk of contact between workers and materials or equipment. It also ensures that a worker is not stranded in an excavation while materials or equipment are brought into or out of the excavation. The access way must also have rest platforms every five metres or less, or have a suitable cage or safety device to allow the worker a rest break or protection while entering or exiting the shaft or tunnel excavation. Emergency procedures to remove the worker from the shaft or tunnel excavation must be in place and clearly communicated to all workers in and around shaft or tunnel excavations.

Whether hoisting workers materials, equipment or excavated material, it is important to inspect all equipment used in the hoisting operation. All cranes or other hoisting equipment must be inspected and maintained according to the manufacturer's specifications, or as required under Part 23 of the Workplace Safety and Health Regulation. All records specified in the regulation must be kept in the crane's logbook, in the crane. All ropes, cables, chains, blocks and other hoisting apparatus must be regularly inspected for defects or wear to ensure safe use.



## **Atmosphere Conditions**

Shaft and tunnel excavations are considered to be confined entry situations, therefore the requirements in Part 15 of the Workplace Safety and Health Regulation (relating to confined spaces) must be followed. A hazard assessment of the confined space must be conducted and safe work procedures developed and put into place before a worker is allowed to enter the shaft or tunnel. Specific requirements also exist for ventilation in shaft and tunnel excavations. The ventilation system must ensure a ventilation rate of at least 0.25 cubic metres per second per square metre of face (50 cubic feet/minute per square foot of face area). This system must also reduce and maintain concentration of toxic vapours, aerosols, dusts and other harmful elements at levels safe for workers.

Because there is little or no natural light in a shaft or tunnel excavation, lighting must be provided where workers may be working in the excavation. The lighting source must provide at least five decalux of light. In addition to this lighting source, emergency lighting must be available in case the original lighting source fails.

All electrical work and installations in shaft and tunnel excavations must meet the requirements of the Manitoba electrical code. Light bulbs must be caged to protect against physical damage. Only electrical equipment and tools that are double insulated or properly grounded may be used. GFCI's (ground fault circuit interrupters) should be used for all circuits underground, because of the high moisture levels.

## **Fire Protection**

Fire protection must be considered in each shaft and tunnel excavation, depending upon the equipment and materials used in the excavation. Flammable and combustible materials must be properly stored according to the Manitoba fire code. Safe work procedures must be developed and in place when work might introduce a fire hazard.

## **Explosives**

If explosives are used in a shaft or tunnel excavation, all blasting must meet the requirements of Part 34 of the Workplace Safety and Health Regulation relating to explosives.

## **Communication**

When hoisting is in progress, workers must be located at both the top and bottom of the shaft to supervise the hoist activity. A communication system must be in place between the workers at the top and bottom of the shaft, as well as any workers that may be on a landing in the shaft leading to tunnels or underground spaces.

## **Machinery and Equipment**

Machinery and equipment used in shaft and tunnel excavations may create additional hazards that need addressing. Specifically, internal combustion engines are of concern, if used in shaft and tunnel excavations, because of the hazards they introduce. Engines must be equipped with properly maintained exhaust conditioners and engines must be shut down if the ventilation system fails or ceases to operate. Testing must be conducted at least once per shift to ensure no harmful gases are in the work area, and appropriate fire extinguishers must be kept near the engine. If haulage locomotives are used, they must be equipped with properly maintained braking systems, interlocking power controls that only operate from the driver's station and appropriate fire extinguishers.

## DEEP FOUNDATION EXCAVATIONS

Deep foundation excavations are excavations made for a foundation unit that provides support for a building or structure by transferring loads to soil or rock at substantial depth below the building or structure, or by adhesion or friction in the soil or rock where it is placed. Foundation units are typically piles or caissons. When workers are required or permitted to enter a deep foundation excavation, the excavation is considered a confined space, and requirements of Part 15 of the Workplace Safety and Health Regulation (regarding confined spaces) must be followed.

When workers are required to enter deep foundation excavations, support structures must be installed. Support structures for deep foundation excavations must be designed and certified by a professional engineer. The support structure must extend 300 millimetres (12 inches) above the ground level and continue to the point where the work is being carried out. The support structure must be at least 700 millimetres (28 inches) in diameter and be secured against any movement.

Professional engineers must include a way for workers to enter and exit deep foundation excavations in their designs. At all times when inside a deep foundation excavation, workers must wear a full body harness attached to a secured lifeline that meets the requirements of Part 14 of the Workplace Safety and Health Regulation (relating to fall protection). The lifeline must extend to the top of the excavation and be secured to an anchor, as required by the regulation. A worker must be in place continuously to monitor the worker that is in the deep foundation excavation.

A tripod or similar type of hoist must be used to raise or lower workers into or out of deep foundation excavations. The hoist and all cables, hooks (equipped with positive means of securement) and components must be:

- designed and certified by a professional engineer
- inspected regularly to ensure safe operating condition
- a sufficient height to safely raise the worker completely above the ground surface
- equipped with a brake capable of supporting at least four times the maximum load that may be applied to it

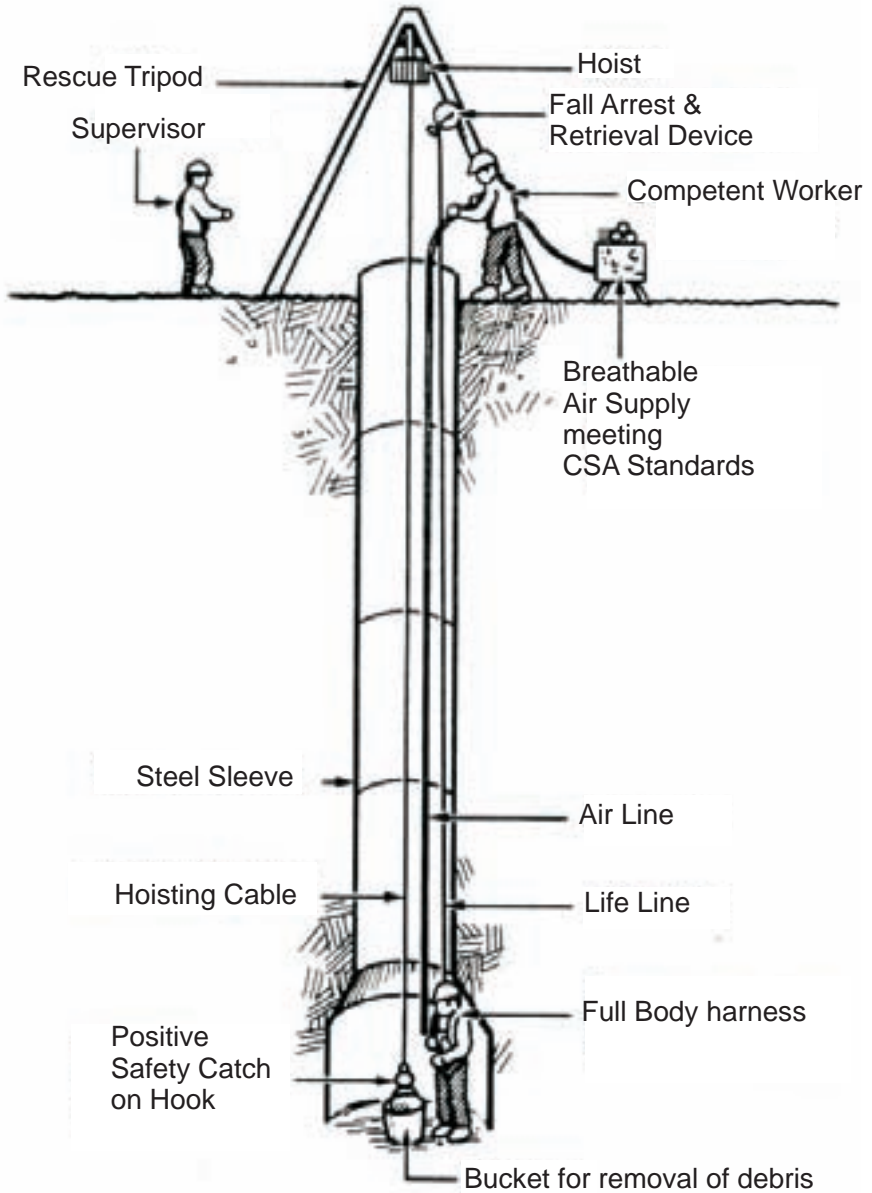

## PILE DRIVING

Many construction projects use piles for deep foundations. Piles are used to support foundations or secure excavations. Piles are usually driven into position with pile hammers mounted on cranes. During the driving process, both the pile and the hammer must be temporarily held in place. Removal methods must also be considered for piles that are used for temporary support.

Appropriate footing must be considered when pile driving equipment will be used at a construction project site.

### Types of hammers

The five common types of hammers used for driving piles include:

- Drop hammers – the most common types of drop hammers used are power assisted drop hammers. With this type, the hammer weight is hung from a rope or cable running over a pulley to a rope drum. The hammer is supported on a frame or leader. The hammer is released manually and drops onto the pile. The hammer is raised back up by a winch.

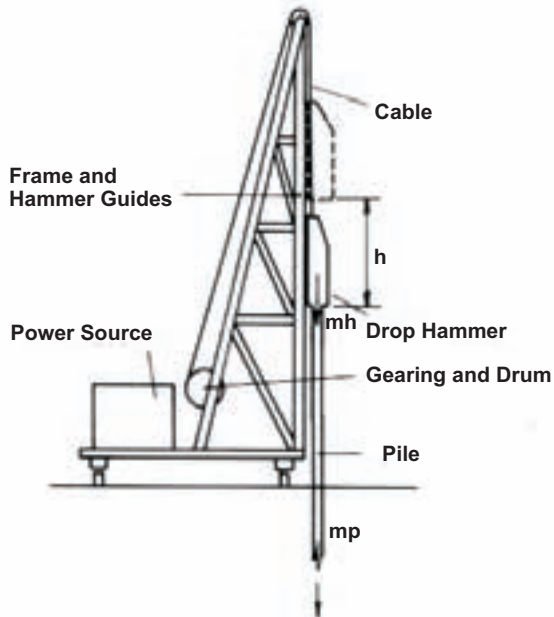

- Single-acting steam, compressed-air or diesel hammers – the steam and compressed-air hammers drive in a similar manner to the drop hammers, but instead of being raised back up with a winch, the hammer is raised by steam or compressed-air. It consists of a part hollow piston rod and sliding cylinder, which must be attached from a sliding guide to leaders or a pile to provide directional control during driving.

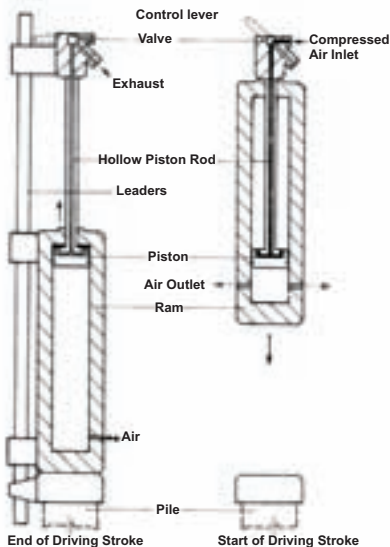

The single-acting diesel hammer works similarly to the steam or compressed-air hammer. It is started by raising the ram, which automatically falls at the top of the stroke. As the ram falls, fuel is injected and compressed, causing an explosion that causes the piston to move up, creating a cycle.

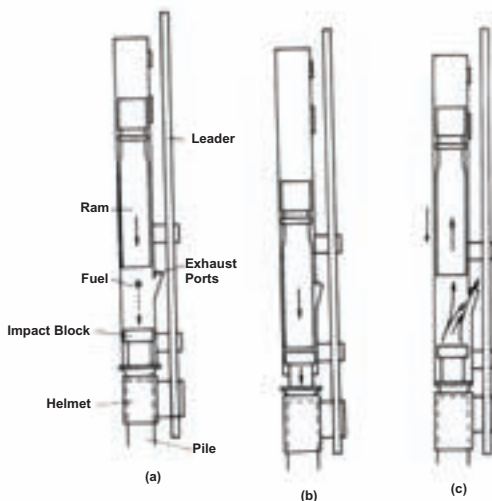

- Double-acting steam, compressed-air, or diesel hammers these hammers use upper and lower cylinders alternately which reduces the stroke of the hammer, but increases the speed at which the hammer strikes. This is beneficial in granular type soils, but less effective in more cohesive soils like clay.

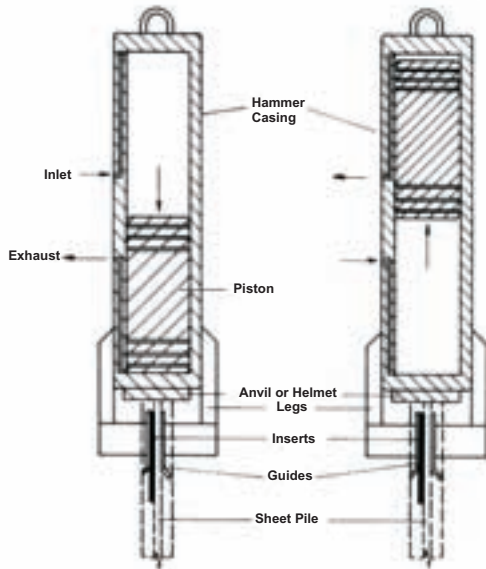

- Vibratory hammers these hammers are most commonly used in areas where there is a demand for a quiet method of driving. The vibrating unit is housed in a steel casing and suspended from the lifting rope of a crane. A suspension bracket eliminates the upward vibration into the rope. The action of the vibrator causes the pile to momentarily shake up, then down, reducing the friction between the pile and soil. The weight of the pile and driver then cause the pile to sink into the soil.

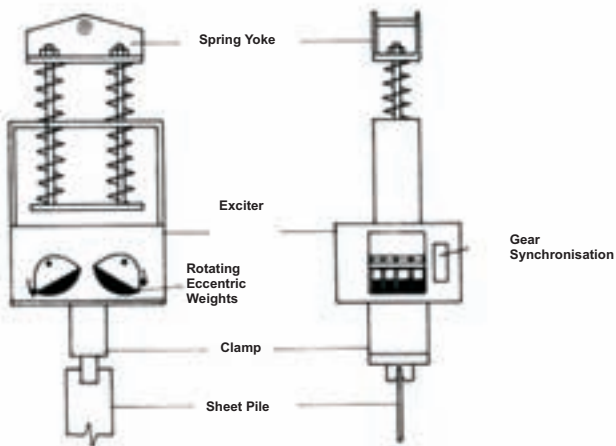

- Hydraulic hammers – these types of hammers are commonly used in more cohesive soils where vibratory hammers are not as effective. Piles, usually seven or eight at a time, are normally placed in a temporary frame for support. The driver is hung from a crane jib. Guide legs maintain alignment with the piles. The piles are driven, by eight hydraulic jacks connected to friction plates, usually starting with the middle piles, working outwards.

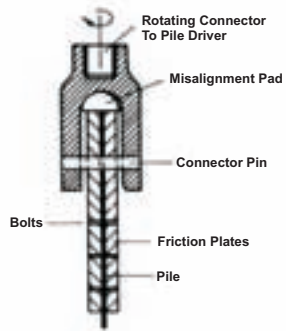
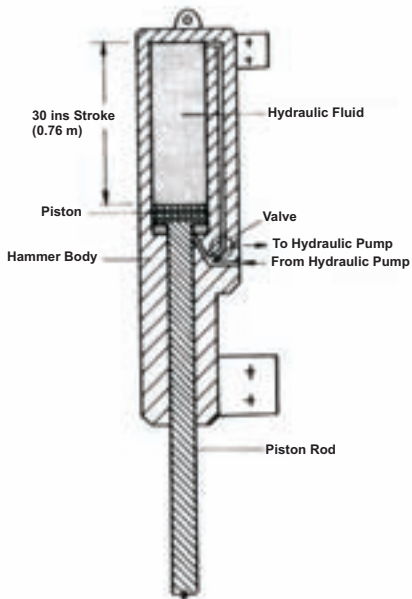
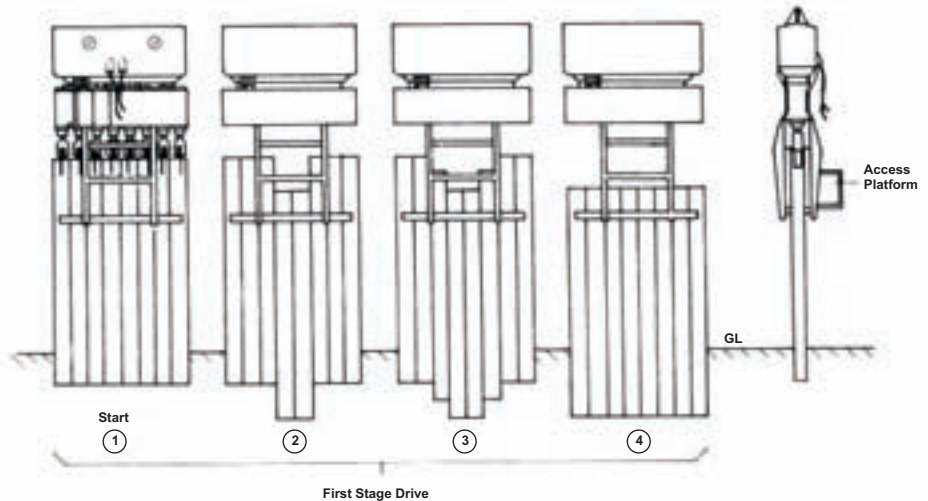



## Safe Work Practices and Procedures

Part 24 of the Workplace Safety and Health Regulation provides minimum requirements for driving or removing piles. Safe work procedures must be developed and in place before any work is done. Safe work procedures need to include transporting piles and the procedure to hoist and drive them. Specific concerns that must be addressed in the safe work practices and procedures:

- operators do not hoist piles in the leads when workers who are not directly involved with the pile driving operation are on the pile driving equipment or within range of the pile if it falls.
- workers are not allowed to remain on or ride on a load being moved, raised or lowered by pile driving equipment.
- workers must be protected from risk should a pile shatter when being struck.
- pile heads must be trimmed to fit the follower on a pile driving cap.
- support piles and sheet piles must be adequately supported to prevent uncontrolled movement.
- a ladder system must be used by a worker who is required to climb on a lead.
- the pile hammer must be secured when the equipment is not in operation.

## Professional Engineer Approval and Inspection

A professional engineer must approve any device used to extract piles. In addition to this approval, a professional engineer must inspect and certify the following:

- crane booms with vibratory hammers – while in use, at intervals of not more than 600 operating hours
- crane booms with vibratory pile extractors – while in use, at intervals of not more than 200 operating hours
- crane booms used for dynamic compaction – while in use, at intervals of not more than 200 operating hours

If out of service, all crane booms and attached equipment for use in driving or extracting piles must be inspected before use.

